



Description :

**DATACENTER IP CABINETS**

**Front glass or blind door, rear blind door and side blind panels**

Datacenter IP cabinets are designed for the containment of all the main types of servers and 19" modular active equipment available in the networking market in environments where it is required a high protection degree. Racks have an IP55 protection degree and are available with a width of 600 or 800 mm and a depth of 1000 mm, equipped with front glass or blind door, rear door and blind side panels.

CODE	DESCRIPTION	DIMENSIONS (mm)			LOADING WEIGHT
		W	D	H	Kg
2009207	Cabinet IP55 19" 600x1000x42U front glass door	600	1000	2218	750
2009205	Cabinet IP55 19" 800x1000x42U front glass door	800	1000	2218	750
2009208	Cabinet IP55 19" 600x1000x42U front blind door	600	1000	2218	750
2009201	Cabinet IP55 19" 800x1000x42U front blind door	800	1000	2218	750



**GENERAL CHARACTERISTICS**

- Steel sheet structure
- Colour: Grey RAL 7035
- Front glass or blind door with 3-point closing system
- Rear blind door with 3-point closing system
- Blind side panels
- Door opening with lever system
- Removable roof
- No. 4 lifting eyebolts
- Brush strip cable entry on the base of the cabinet
- No. 4 numbered 19" uprights in accordance with IEC 60297-1 adjustable in depth
- Holes for the installation under roof of ventilation units
- Side filters for cabinet ventilation with external protective covers
- Plinth of 100 mm height
- IP55 degree of protection in accordance with EN 60529
- Impact resistance rating IK10 for cabinets with blind doors; IK09 for cabinets with glass doors
- Earthing kit
- Loading weight: 750Kg

\*Glass door version



Description :

**DATACENTER IP CABINETS**

**Front glass or blind door, rear blind door and side blind panels**

**TECHNICAL DRAWINGS**

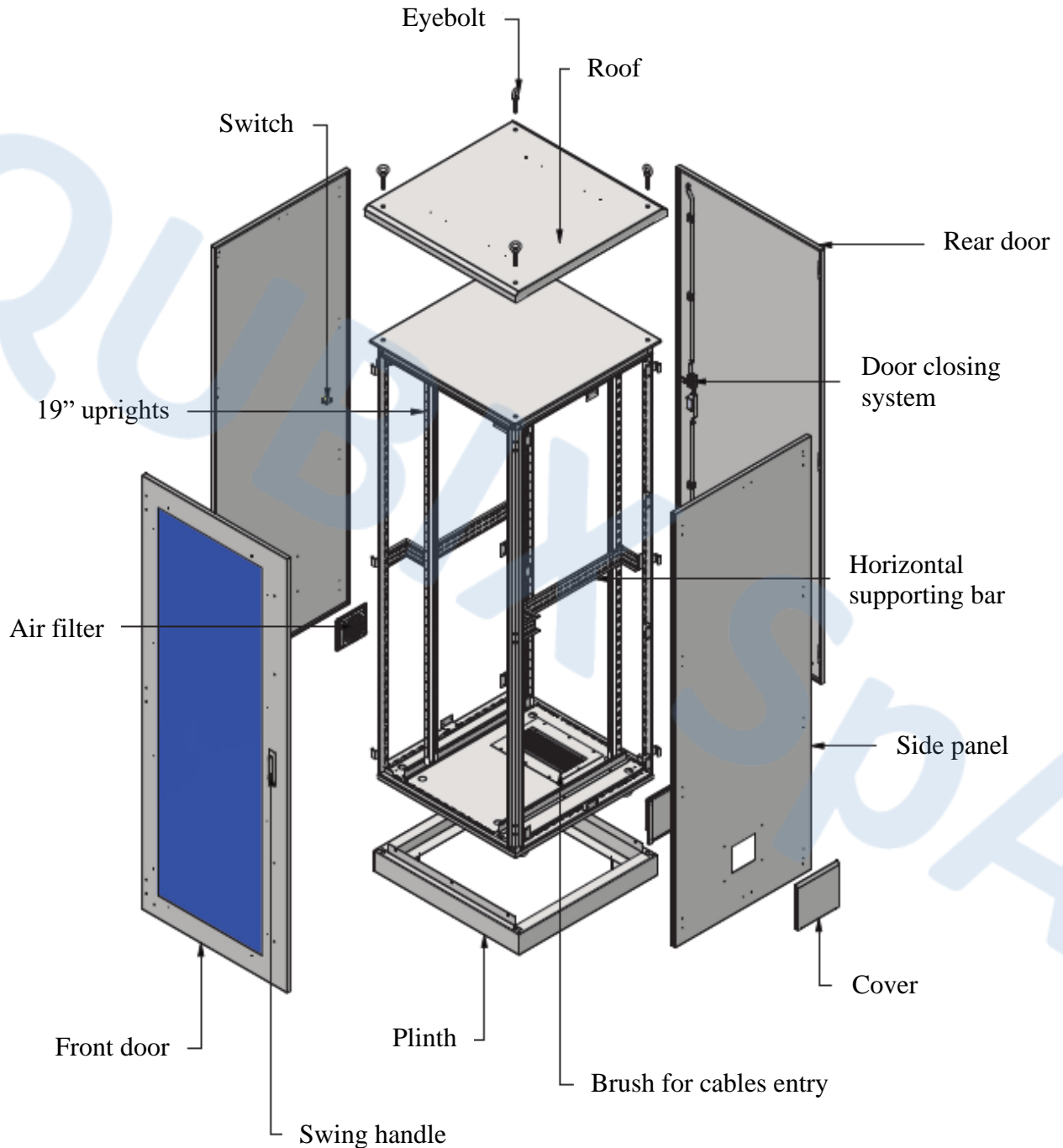

\* The image is for the glass door version



Description :

**DATACENTER IP CABINETS**

**Front glass or blind door, rear blind door and side blind panels**

**TECHNICAL DRAWINGS**

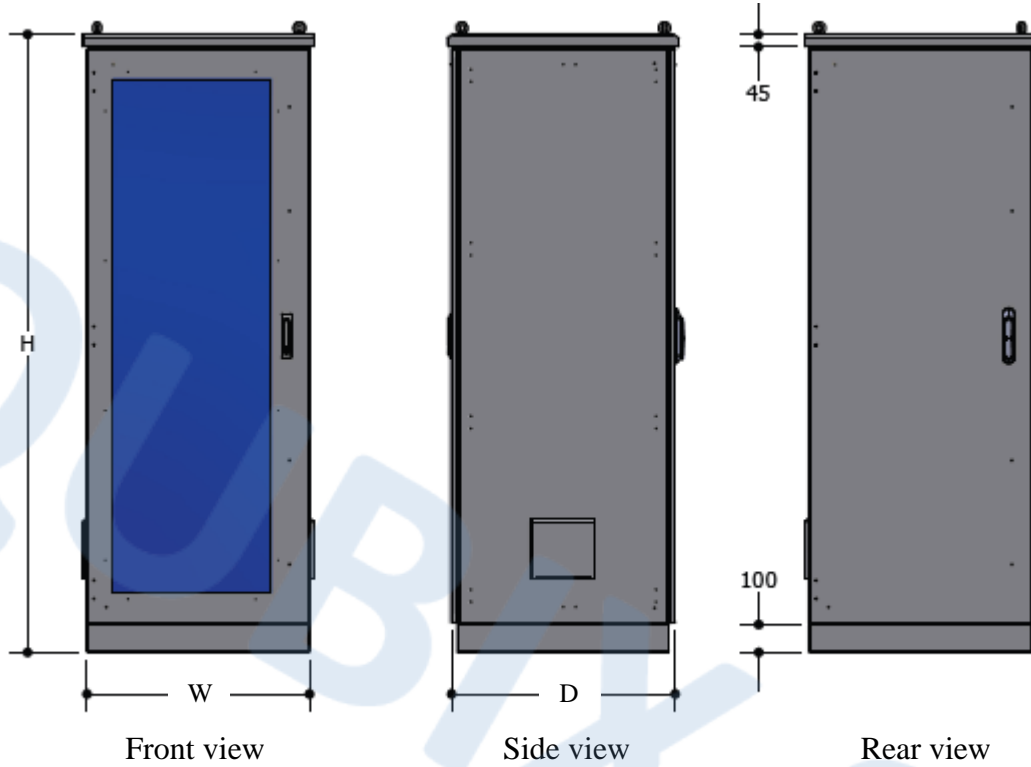

Top view

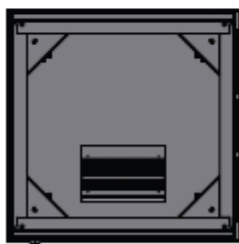

Bottom view

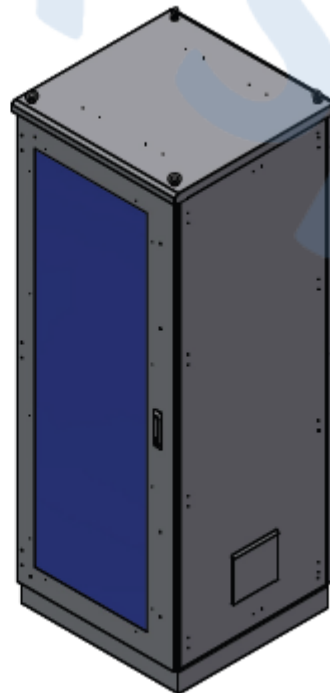

Isometric view

\* Pictures are for the glass door version

QUBIX S.p.A. Networking solutions – Via Canada, 22/A – 35127 Padova – Italy  
Tel. +39 049 7801994 – Fax +39 049 775667 – <http://www.qubix.it>

Rev. 01-23

Qubix S.p.A. si riserva di apportare modifiche e migliorie in qualsiasi momento senza preavviso  
Qubix S.p.A. reserves the right to make changes and improvements at any time without notice