



Description :

FLOOR IP CABINETS

Front glass or blind door, rear blind door and side blind panels

Floor IP cabinets are designed for the containment of the main equipment for structured cabling and LAN networks in environments where it is required a high protection degree. Racks have an IP55 protection degree and are available with a width of 600 or 800 mm and depth of 600 or 800 mm, equipped with front glass or blind door, rear blind door and side blind panels.

CODE	DESCRIPTION	DIMENSIONS (mm)			LOADING WEIGHT
		W	D	H	Kg
2009202	Cabinet IP55 19" 600x600x26U front glass door	600	600	1507	750
2009204	Cabinet IP55 19" 600x800x26U front glass door	600	800	1507	750
2009206	Cabinet IP55 19" 800x800x26U front glass door	800	800	1507	750
2009214	Cabinet IP55 19" 600x600x42U front glass door	600	600	2218	750
2009213	Cabinet IP55 19" 600x800x42U front glass door	600	800	2218	750
2009229	Cabinet IP55 19" 800x800x42U front glass door	800	800	2218	750
2009203	Cabinet IP55 19" 600x600x26U front blind door	600	600	1507	750
2009209	Cabinet IP55 19" 600x800x26U front blind door	600	800	1507	750
2009211	Cabinet IP55 19" 800x800x26U front blind door	800	800	1507	750
2009215	Cabinet IP55 19" 600x600x42U front blind door	600	600	2218	750
2009212	Cabinet IP55 19" 600x800x42U front blind door	600	800	2218	750
2009200	Cabinet IP55 19" 800x800x42U front blind door	800	800	2218	750



* Glass door version

GENERAL CHARACTERISTICS

- Steel sheet structure
- Colour: Grey RAL 7035
- Front glass or blind door with 3-point closing system
- Rear blind door with 3-point closing system
- Blind side panels
- Door opening with lever system
- Removable roof
- No. 4 eyebolts for lifting the cabinet
- Brush strip cable entry on the base of the cabinet
- No. 4 numbered 19" uprights in accordance with IEC 60297-1 adjustable in depth
- Holes for the installation of ventilation units under the roof
- Side filters for cabinet ventilation with external protective covers
- Plinth of 100 mm height
- IP55 degree of protection in accordance with EN 60529
- Impact resistance rating IK10 for cabinets with blind doors; IK09 for cabinets with glass doors
- Earthing kit
- Loading weight: 750Kg



Description :

FLOOR IP CABINETS

Front glass or blind door, rear blind door and side blind panels

TECHNICAL DRAWINGS

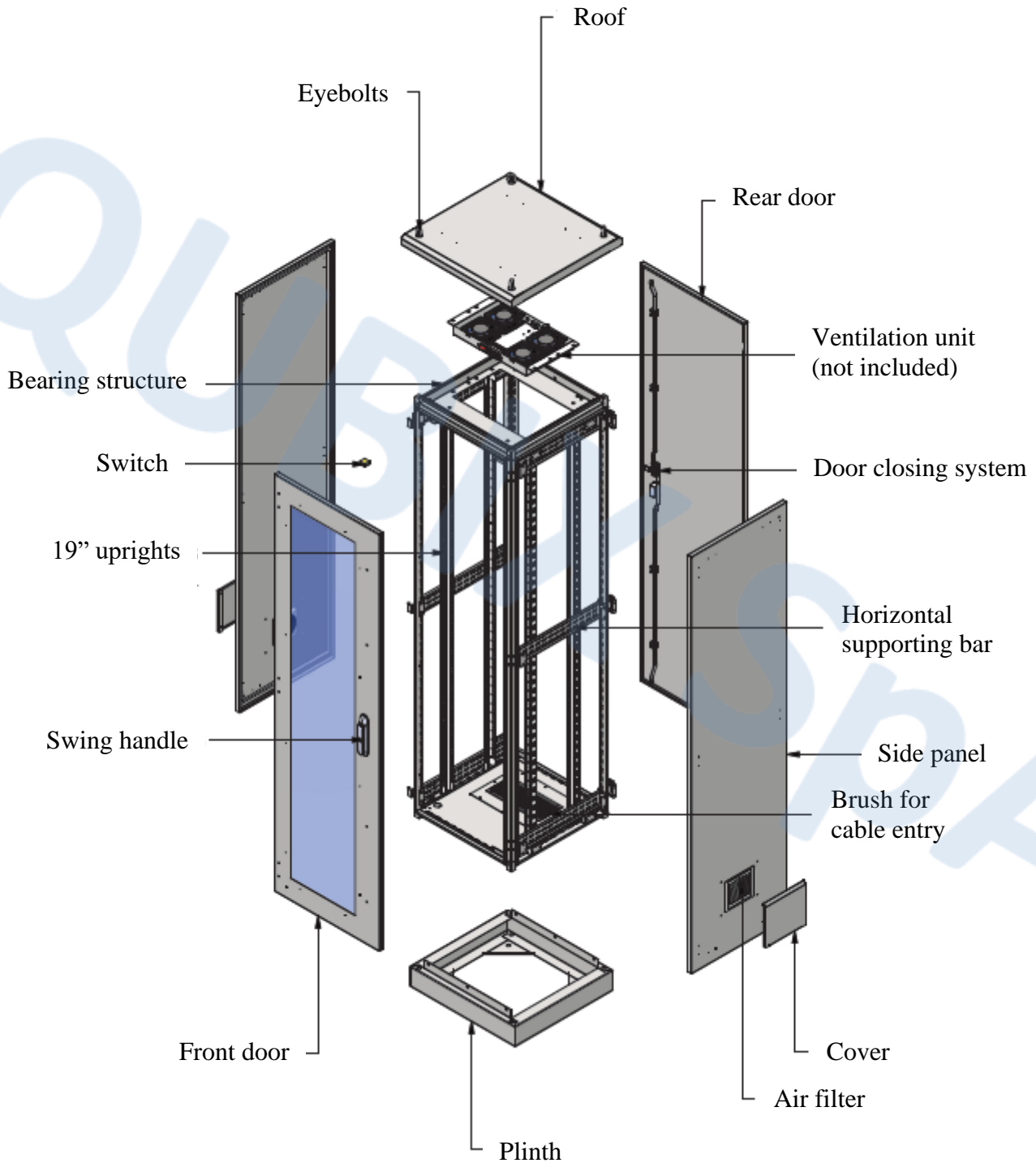

* The image is for the glass door version



Description :

FLOOR IP CABINETS

Front glass or blind door, rear blind door and side blind panels

TECHNICAL DRAWINGS

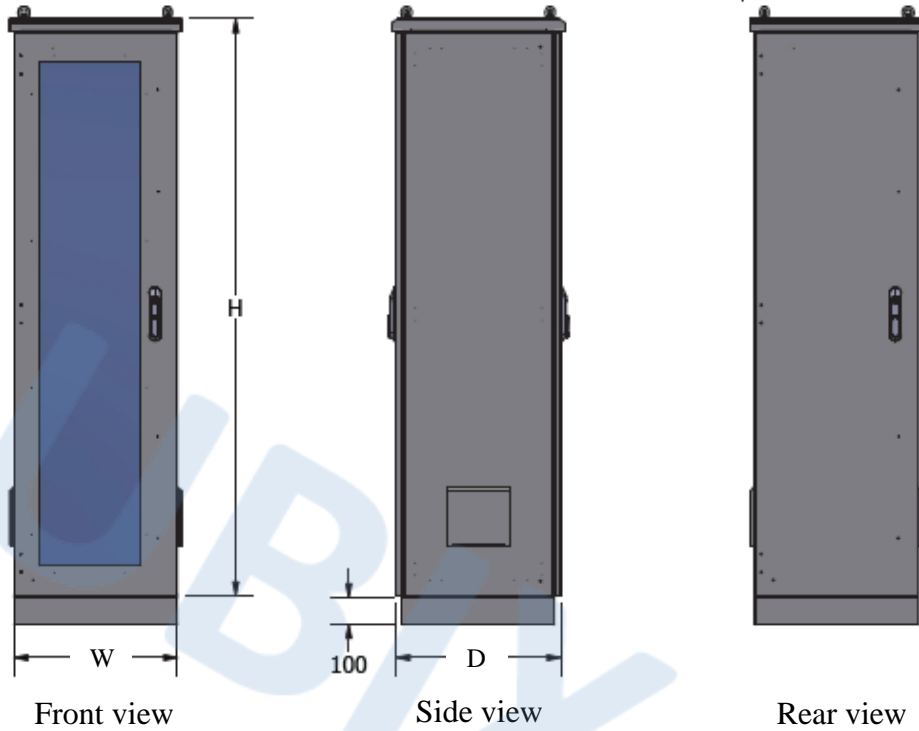

Top view

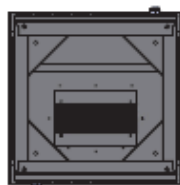

Bottom view



Isometric view

* Pictures are for the glass door version