



Description :

FLAT PACK WALL MOUNTED TECH CABINETS
Front glass door and side blind panels

Flat Pack wall mounted TECH cabinets are designed for the containment of the main equipment for structured cabling and LAN networks. They have a depth of 450 or 600 mm, unassembled in flat pack packaging, equipped with front glass door and side removable blind panels, colour black RAL 9005.

CODE	DESCRIPTION	DIMENSIONS (mm)			LOADING WEIGHT
		W	D	H	Kg
2020031NF	Cabinet 19" 570x450x6U Flat Pack, black	570	450	370	60
2020032NF	Cabinet 19" 570x450x9U Flat Pack, black	570	450	500	60
2020042NF	Cabinet 19" 570x600x9U Flat Pack, black	570	600	500	60
2020034NF	Cabinet 19" 570x450x12U Flat Pack, black	570	450	635	60
2020044NF	Cabinet 19" 570x600x12U Flat Pack, black	570	600	635	60
2020035NF	Cabinet 19" 570x450x15U Flat Pack, black	570	450	770	60
2020045NF	Cabinet 19" 570x600x15U Flat Pack, black	570	600	770	60
2020046NF	Cabinet 19" 570x600x22U Flat Pack, black	570	600	1080	60



Flat Pack

GENERAL FEATURES

- Frame in steel sheet
- Finishing colour black RAL 9005
- Front safety glass door with lock and keys, opening over 180°
- Removable blind side panels
- Top and bottom cable inlets
- Ventilation slots for air outlet on top and bottom, suitable for the installation of ventilation fans on the top
- IP20 degree of protection
- No. 2 vertical uprights adjustable in depth to install 19" standard equipments
- Static load: 60 kg



Description :

FLAT PACK WALL MOUNTED TECH CABINETS
Front glass door and side blind panels

TECHNICAL DRAWINGS

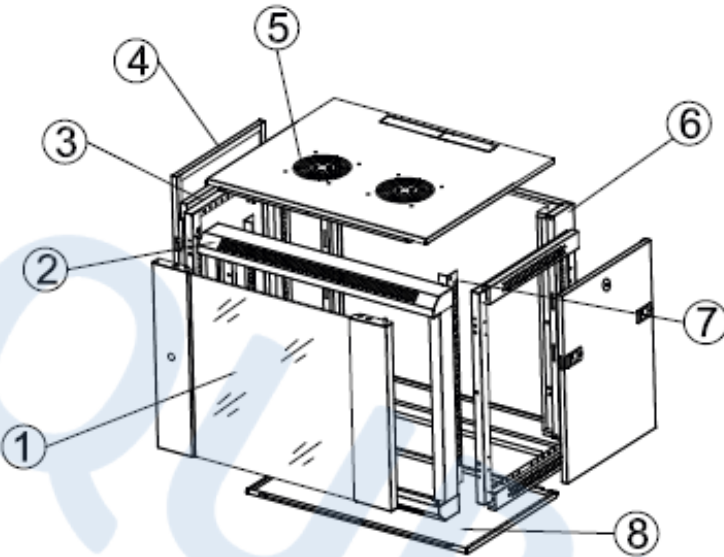

COMPONENT	DESCRIPTION
# 1	Front glass door - 1 pc
# 2	Front frame - 1 pc
# 3	Side frames - 2 pcs
# 4	Side panels - 2 pcs
# 5	Top panel - 1 pc
# 6	Rear frame - 1 pc
# 7	19" uprights - 2 pcs
# 8	Bottom panel - 1 pc

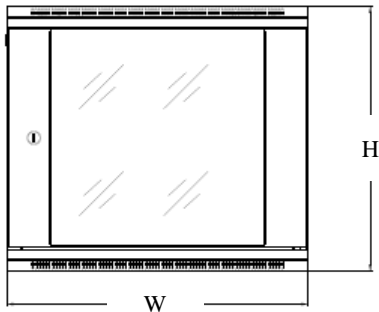

Front view

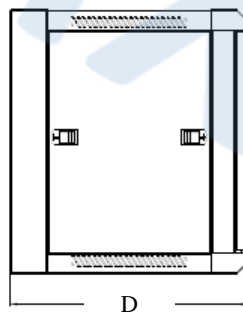

Side view

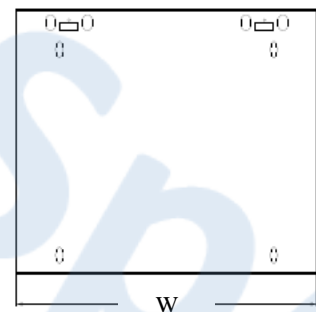

Rear view

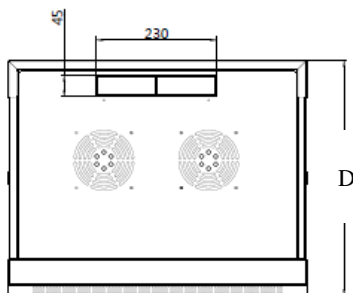

Top view

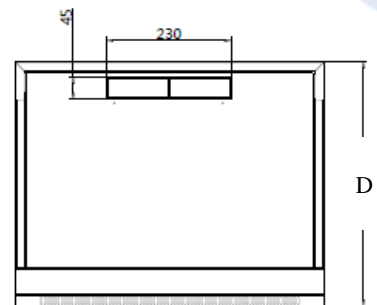

Bottom view